



PANEL SAWS



English



RS **ROBLAND**[®]
MADE IN BELGIUM

TABLE OF CONTENTS

About Robland	3 - 5
NXZ	6
E300	7
E2500	8
Options & accessories - E-series	9
Strengths	10 - 11
Z-series	12 - 13
Z300	14
Z400	15
Z500	16
Outrigger tables	17
Options & accessories - Z-series	18 - 19
Selection criteria	20 - 21
ROBLAND machines overview	22 - 23
Disclaimer & contact details	24

MADE IN BELGIUM

SINCE 1968

ROBLAND is a privately owned Belgian company, that was founded in 1968 by Robert Landuyt. The first successes were achieved by building affordable qualitative universal woodworking machines, a large part of which are still in use today.

We do have all resources and competencies in house for product development, parts manufacturing, product assembly, sales and after sales support.

With our state of the art, highly automated, parts manufacturing machines we are able to remain cost effective while manufacturing in Belgium near the historical city of Bruges. Although our machines will last for years, this is not enough for us. A quality service and after sales support is key to ROBLAND's success. As we manufacture all machine parts ourselves, you can rely on spare parts always being rapidly available.

Our company mission is to offer woodworking machines with the best quality/price ratio to the high end Do-It-Yourself market and to the small and medium-sized enterprise market.

Our product portfolio, aimed at the second wood processing, includes panel saws, table saws, universal machines, planers, thicknessers, spindle moulders, horizontal mortisers, a semi-automatic boring machine, a CNC boring machine, edgebanders and dust extraction systems.

We have an international dealer network and currently export over 85% of our production worldwide to more than 100 countries. In its 20.000 m² large factory ROBLAND employs over 80 people.

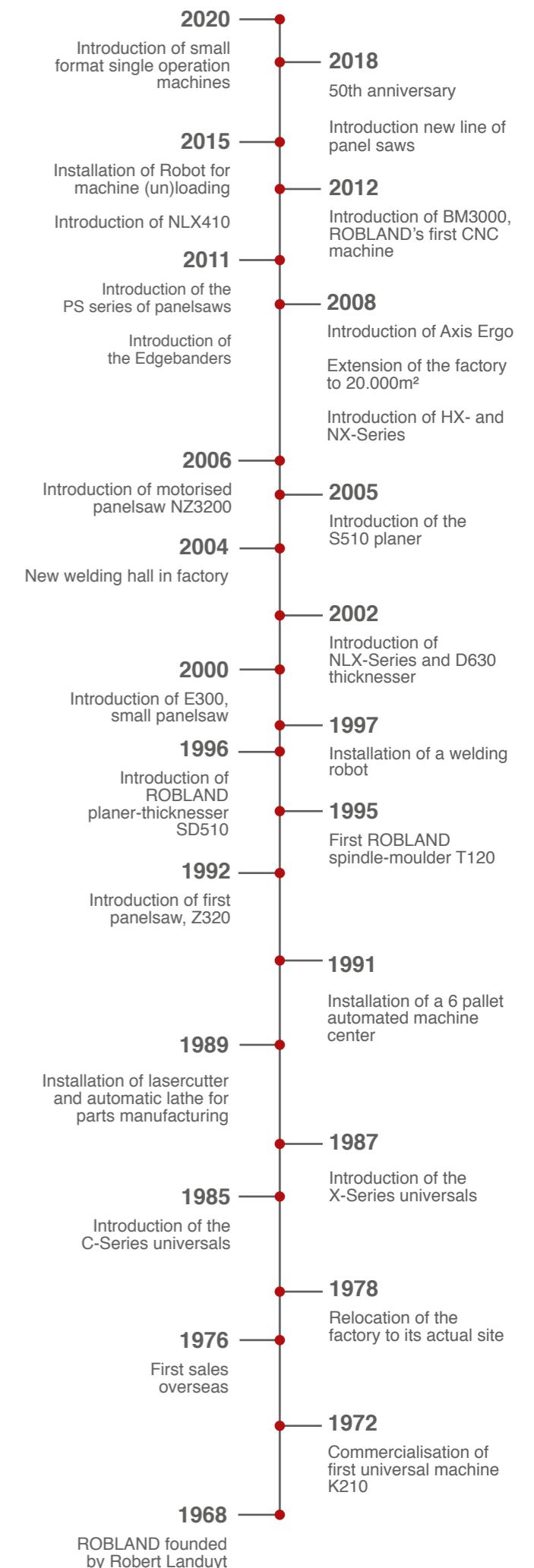

PRODUCTION



Steel plate laser cutting



Computer assisted steel plate bending



Welding of frame



Powder coating



Milling of sliding table surface



Surface scraping of cast iron table



Edge milling of cast iron table



CNC Machining of cast iron table



CNC Machining of cast iron saw aggregate



CNC Manufacturing of steel parts

SUBASSEMBLY



ASSEMBLY



LEVELLING AND ALIGNMENT OF THE SLIDING TABLE

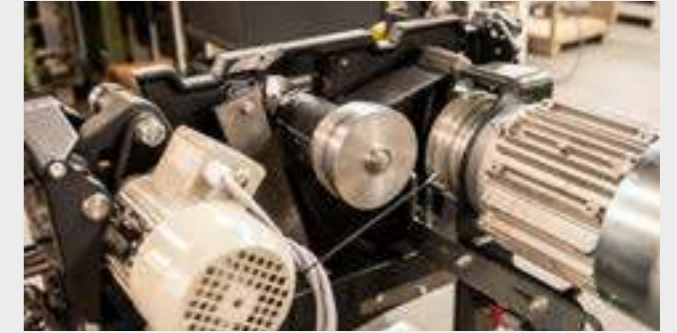



NXZ with options



E300 with options

NXZ Technical data

Weight	385 kg
Voltage	230 V mono / 230 V 3 Phase / 400 V 3 Phase
Motor 3 phase	3,7 kW / 5 hp (S6)
Motor single phase	2,2 kW / 3 hp (S6)

Versions

250 mm	with scoring unit (100 x 20 mm)
315 mm	without scoring unit

Saw

Saw blade rotation speed	4500 RPM
Diameter saw blade (250 mm version)	250 x 30 mm + 100 x 20 mm scoring unit
Diameter saw blade (315 mm version)	315 x 30 mm
Cutting depth at 45° / 90° (250 mm version)	55 mm / 85 mm
Cutting depth at 45° / 90° (315 mm version)	75 mm / 107 mm
Cutting length	1600 mm (option 2000 mm / 2500 mm)
Cutting width parallel fence	900 mm
Dimensions table	1080 x 410 mm
Dimensions sliding table	1450 mm (option 2050 mm) x 320 mm
Dust extraction outlets	100 mm + 60 mm

E300 Technical Data

Weight	437 kg
Voltage	230 V mono / 230 V 3 phase / 400 V 3 phase
Motor power 3 phase	4,4 kW / 6,6 hp (S6)
Motor single phase	3 kW / 4 hp (S6)
Rotation speed main saw	4500 RPM
Max. saw diameter	300 mm
Max. depth of cut at 90° (45°)	100 mm (70 mm)
Cutting length	1700 mm
Cutting width parallel fence	1200 mm
Sawblade bore	30 mm
Motor power scorer	0,75 kW / 1 hp (S6)
Rotation speed scoring saw	6500 RPM
Scoring sawblade	120 x 20 mm
Cutting depth scorer	4,5 mm
Dimensions sliding table	1700 x 310 mm
Dimensions table extension	720 x 450 mm
Dimensions sawtable	940 x 510 mm
Dimensions cross-cut table	1060 x 510 mm
Dust extraction outlets	100 mm + 60 mm / 100 mm with overhead sawguard

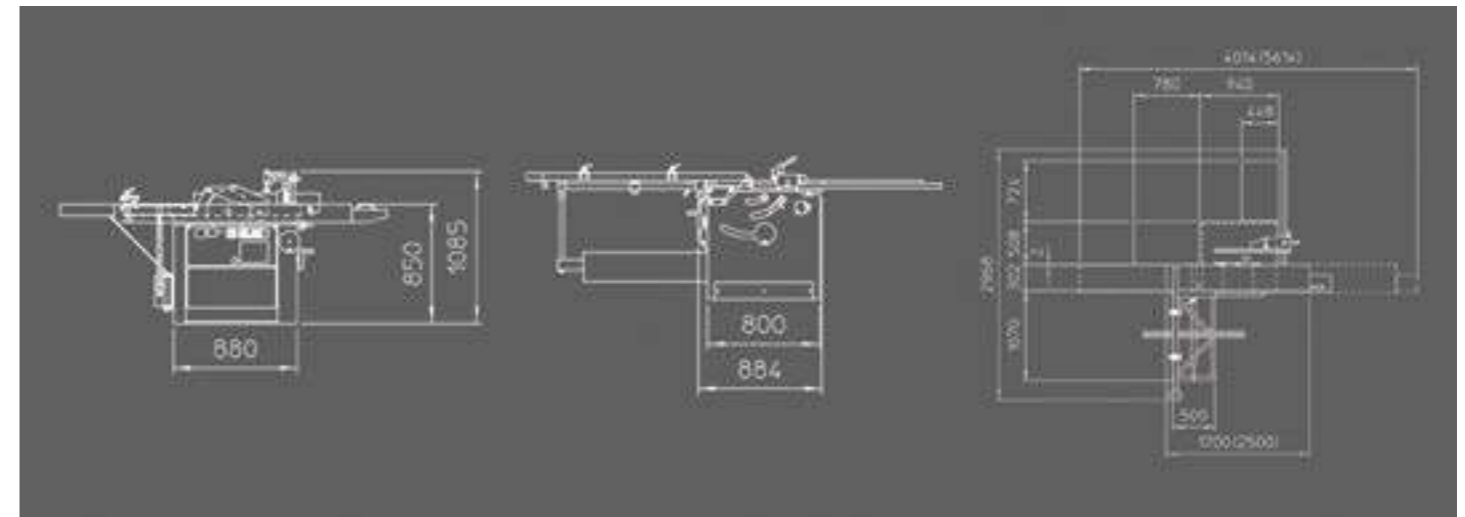
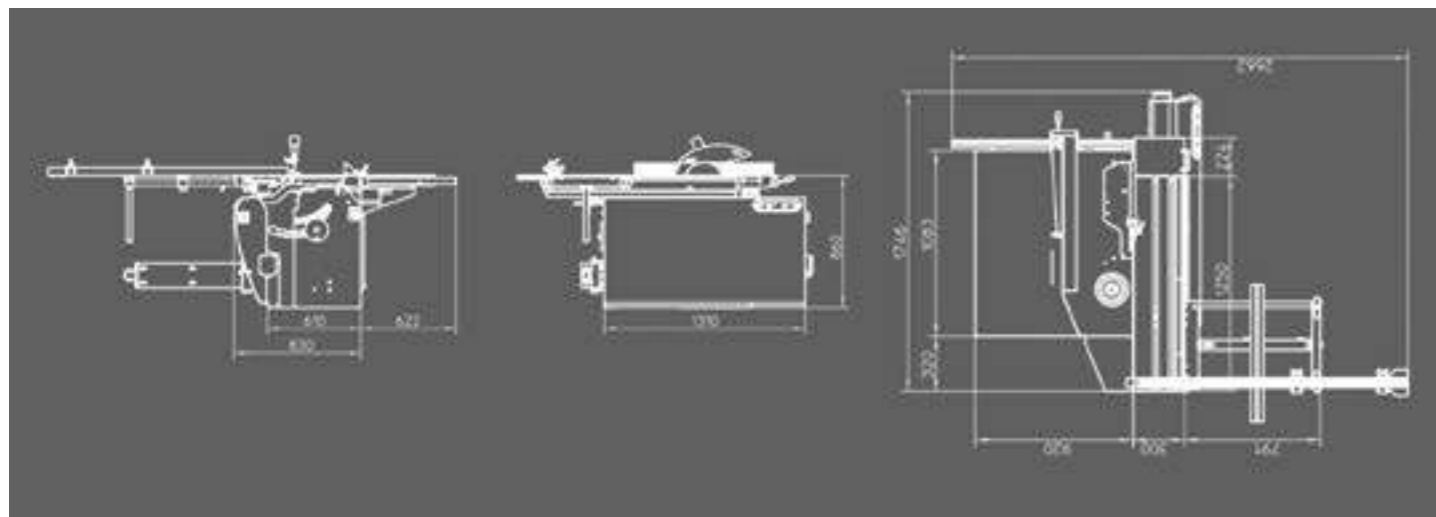



E2500 with options

E2500 Technical Data

Weight	505 kg
Voltage	230 V mono / 230 V 3 phase / 400 V 3 phase
Motor power (3 phase)	4,4 kW / 6,6 hp (S6)
Motor power single phase	3 kW / 4 hp (S6)
Rotation speed main saw	4500 RPM
Max. saw diameter	300 mm
Max. depth of cut at 90° - 45°	100 mm (70 mm)
Cutting length	2500 mm (option 2800 mm / 3100 mm)
Cutting width	1200 mm
Sawblade bore	30 mm
Motor power scoring saw (option)	0,75 kW / 1 hp (S6)
Rotation speed scoring saw (option)	6500 RPM
Scoring sawblade (option)	120 x 20 mm
Cutting depth scoring saw (option)	4,5 mm
Dimensions sliding table	2850 x 310 mm
Dimensions table extension	720 x 450 mm
Dimensions sawtable	940 x 510 mm
Dimensions cross-cut table	1060 x 510 mm
Dust extraction outlets	100 mm + 60 mm / 100 mm with overhead sawguard

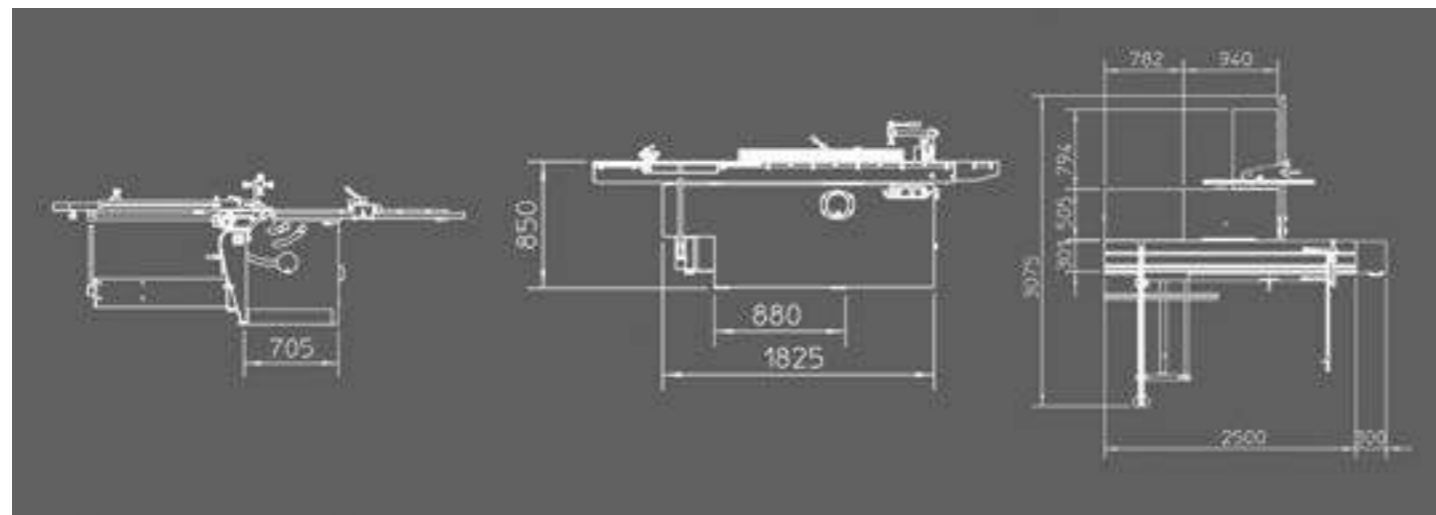

SUPPORT

Extra support table

Can be positioned anywhere along the aluminium profile of the sliding table. Together with the outrigger table it offers a better support for large panels.



DIGITAL READ-OUTS

Digital read-out on parallel fence with micro adjustment (E2500)

This increases ease of use and accuracy.

A digital read-out on the cross-cut fence is available as well.



OVERHANGING DUST EXTRACTION TUBE

An overhanging dust extraction tube can be mounted on the sawblade protection. It offers a standard dust extraction outlet of 100 mm.

(NXZ, E300, E2500, Z300)



SAW GUARD

Overhanging saw guard (E300 & E2500)

For optimum safety and dust extraction, the overhanging saw guard mechanically adjusts to the height of the workpiece. The arm is easy to turn away.



SCORING UNIT

- Optional on the NXZ & E300
- Standard on the E2500
- Diameter 120 mm, driven by separate motor on E-series
- Diameter 100 mm, belt-driven on NXZ

(Scoring blade is not included)

STRENGTHS

COMMON TO ALL ROBLAND PANEL SAWS



TORSION TUBE

A torsion tube filled with concrete offers increased rigidity to the frame, absorbs vibrations and functions as a counterweight for the load on the sliding table.

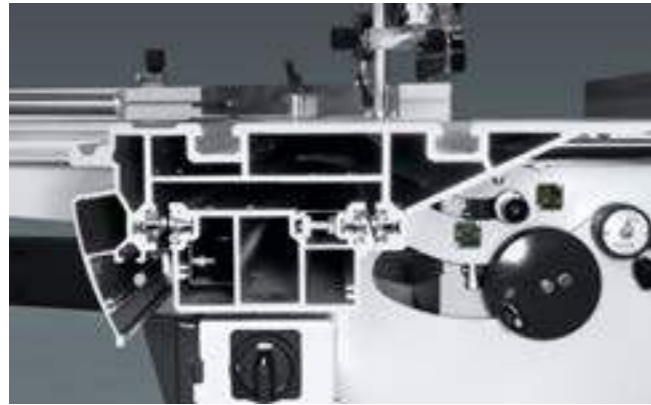

ALUMINIUM SLIDING TABLE WITH BOSS

The aluminium sliding table is completely anodized for better hardness and rust protection. The surface of the sliding table of the Z400 and Z500 is the widest in the industry (426 mm). The Robland bearing system with hard balls on hardened steel round bars (BOSS) and automatic cleaning system ensures a smooth operation.

On every available panel saw of any brand a too hard impact on the carriage inflects an imprint on the lower profile. On any other sliding table, the upper profile has to be dismantled and has to be fixed in a complex way. Thanks to the BOSS-system, the end user can turn the steel round bars himself to obtain a new rolling surface. This way you can enjoy a perfect course of your table for many years.

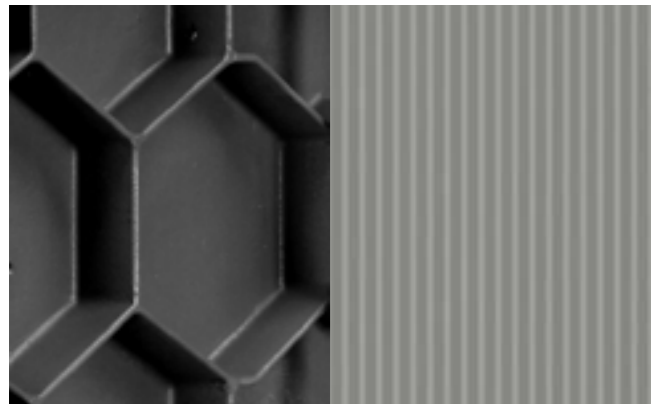

CAST IRON TABLES

Our cast iron tables have a honeycomb structure for the highest strength per weight ratio. The surface is scraped. This technique with low energy dissipation guarantees a very flat surface. Microgrooves are applied for easy gliding of the wooden workpiece on the cast iron table.



OVERHANGING SAW GUARD

For optimal safety and dust extraction, the overhanging saw guard (optionally available as of E300, standard as of Z400 CE) mechanically adjusts to the height of the workpiece. The arm is easy to turn away. On the Z500 the angled support arm allows the cross cut of longer workpieces with a width of up to 850 mm, perfect for kitchen worktables.

STRENGTHS

SPECIFIC TO THE Z300, Z400, Z500 SERIES

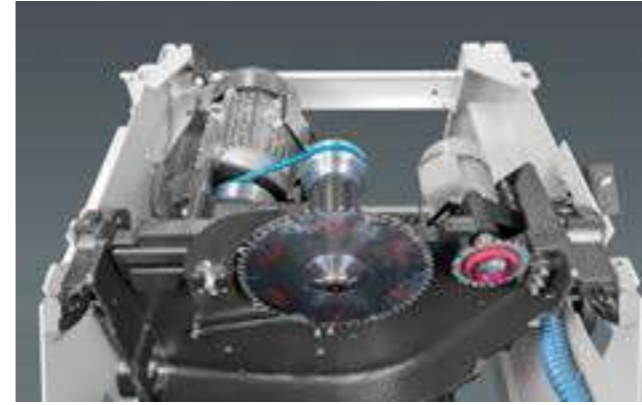

OPTIMIZED SAW AGGREGATE

The saw aggregate is made out of one piece in cast iron for natural absorption of vibrations and offers more precision and stability. Its aerodynamic design allows for optimal dust extraction. The heavy, cast-iron sawing unit rotates on large shells. The system is maintenance-free and guarantees lifelong accuracy as well as smooth movements.



DIGITAL READ-OUT

The Double Digital Flippers (DDF) system allows for a digital read-out of the position along the full length of the first part of the outrigger fence. It increases both ease of use and accuracy. The right flipper is used for measurements close to the sawblade while the left flipper allows to measure larger panels.

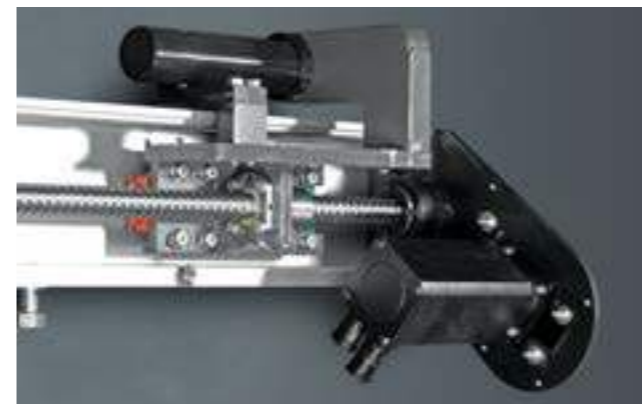

MOTORIZED PARALLEL FENCE

The control of the movement of the parallel fence on a ball screw allows for its very accurate positioning (X1 and X3 versions)



LED STRIP WARNING

On the Z500 models a led strip lights up near the scoring blade when it is in use. This is also available as an option on the Z400 models.

Z SERIES DIFFERENT SAW DIAMETERS

In 2018 ROBLAND launched a new series of panel saws on the basis of different saw diameters, sliding tables and executions. Here you have an overview:

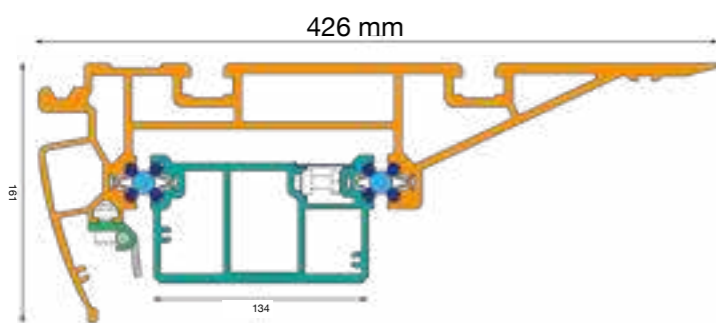
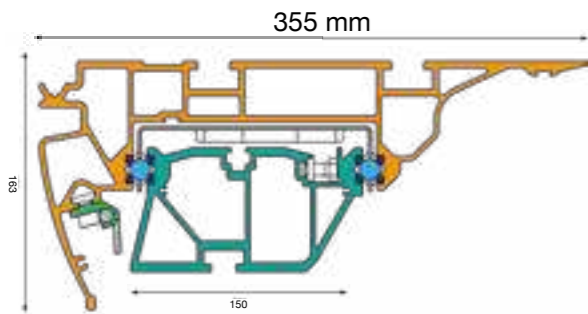
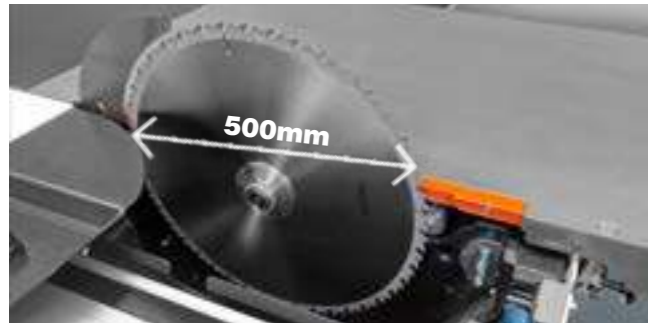
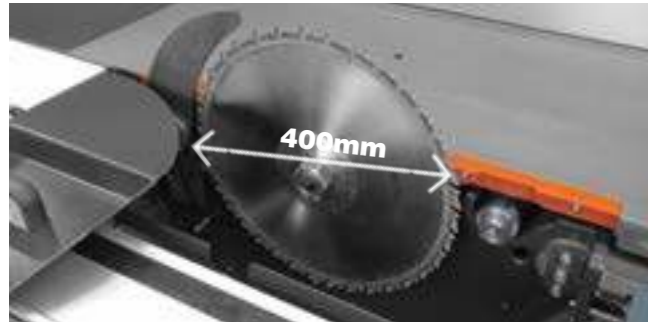
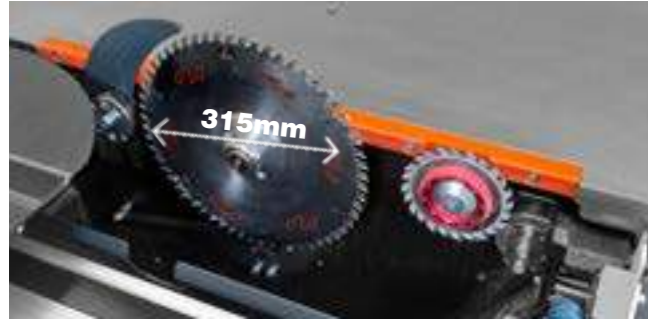

Z300 Series

Maximum saw blade diameter: 315 mm

Z400 Series

Maximum saw blade diameter: 400 mm / 350 mm with mounted scoring blade

Z500 Series

Maximum saw blade diameter: 500 mm / 350 mm with mounted scoring blade

SLIDING TABLE Z300

- Balls on steel bar system (BOSS)
- 6 Years warranty
- 30 steel ball bearings

Available in lengths 2200 / 2800 / 3200 / 3800 mm
Cutting lengths: 2500 / 3100 / 3500 / 4100 mm

SLIDING TABLE Z400 / Z500

- Balls on steel bar system (BOSS)
- 6 Years warranty
- 30 steel ball bearings

Available in lengths 2200 / 3200 / 3800 mm
Cutting lengths: 2500 / 3500 / 4100 mm

Z SERIES DIFFERENT EXECUTIONS



MANUAL (M)

Manual height and tilt adjustment of the saw blade with analogue read-out of inclination of the saw blade.

ELECTRIC (EL)

Electrical height and angle adjustment of the saw blade.

Here pictured with the optional digital read-out of height and inclination of the saw blade.

1 AXIS CONTROL (X1)

Overhanging control panel with:

- 7" state of the art touch screen for numerical control of position of the parallel fence and read-out of height and inclination of the saw blade.
- Push buttons for:
 - Start/stop of the saw blade and scoring blade
 - Height and inclination of the saw blade
 - Emergency stop
- Clipboard for instructions

3 AXIS CONTROL (X3)

Overhanging control panel with 7" state of the art touch screen controlling the position of the parallel fence as well as the height and angle adjustment of the saw blade.

- Push buttons for:
 - Start/stop of the saw blade and scoring blade
 - Emergency stop
- Clipboard for instructions

Z300



Z300 with options

Z400



Z400 with options

Z300 Technical Data

Weight	780 kg - 980 kg
Voltage	400 V 3 phase / 230 V 3 phase
Motor power (3 phase)	4,4 kW / 6,6 hp (S6), option 7 kW / 9,5 hp (S6)
Dust extraction outlets	100 mm in frame + 60 mm on small saw protection 100 mm with overhead saw guard

Saw

Saw blade rotation speed	4000 RPM (option 3000 / 4000 / 5000 RPM)
Diameter saw blade and bore	315 mm
Sawblade tilting	90° - 45°
Cutting depth at 90° / 45°	82,5 mm / 60 mm
Cutting width parallel fence version Z300 M, Z300 EL	1250 mm (option 700 / 1000 / 1350 mm)
Cutting width parallel fence version Z300 X1, Z300 X3	1250 / 1500 mm
Cutting length	3500 mm (option 2500 mm / 3100 / 4100 mm)
Dimensions cast iron table	985 mm x 710 mm
Dimensions sliding table	355 mm x 3200 mm (option 2200 / 2800 mm)
Dimensions cross-cut table	1000 mm x 550 mm
Length of swiveling cross-cut fence	1565 mm + telescopic extension to 2550 mm

Scoring unit

Diameter scoring blade and bore	120 mm, 20 mm
Cutting depth with 120 mm diameter blade	3,5 mm
Scoring blade rotation speed	8200 RPM
Scoring saw motor power	0,75 kW / 1hp (S6)

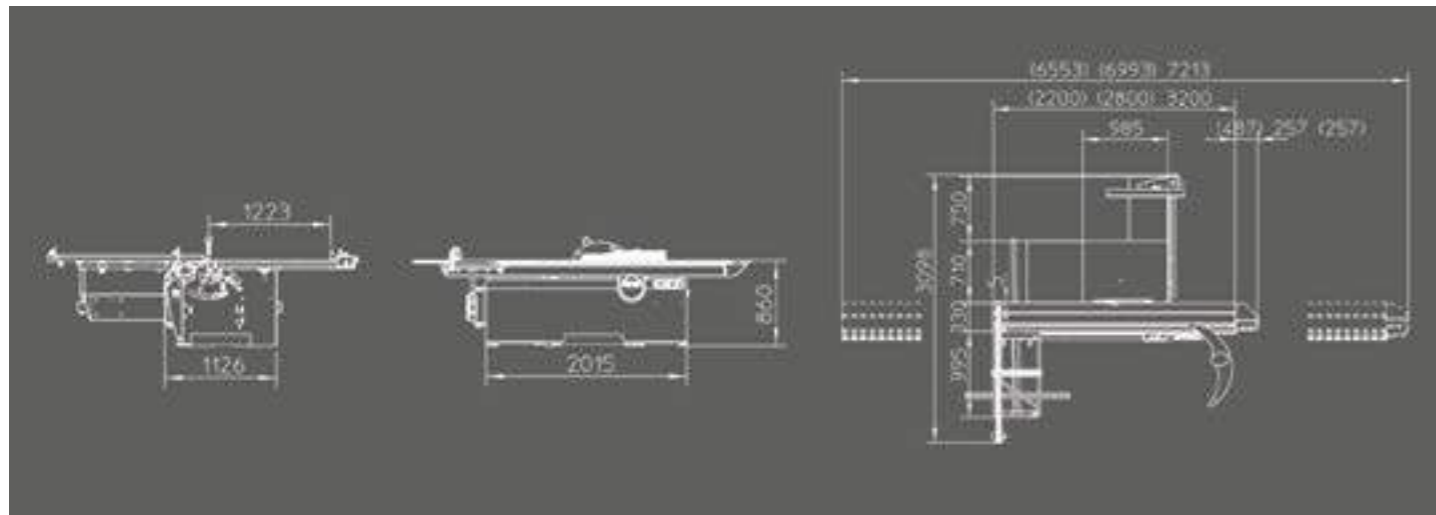

Z400 Technical Data

Weight	850 kg (Z400 - 3200) - 1080 kg (Z400 X3 - 3800)
Voltage	400 V 3 phase (option 230 V 3 phase)
Motor power (3 phase)	7 kW / 9,5 hp (S6), option 9,2 kW / 14 hp (S6)
Dust extraction outlets	100 mm in frame + 60 mm on small saw protection (non CE version) 100 mm with overhead saw guard

Saw

Saw blade rotation speed	3000 / 4000 / 5000 RPM
Diameter saw blade and bore	300 - 400 mm, 30 mm
Sawblade tilting	90° - 45°
Cutting depth at 90° / 45°	125 mm / 90 mm
Cutting width parallel fence, version Z400 M, Z400 EL	1350 mm (option 1000 / 1525 mm)
Cutting width parallel fence, version Z400 X1, Z400 X3	1250 (option 1500 mm)
Cutting length	3500 mm (option 2500 mm / 4100 mm)
Dimensions cast iron table	985 mm x 710 mm
Dimensions sliding table	3200 (option 2200 mm / 3800) mm x 420 mm
Dimensions cross-cut table	1420 mm x 650 mm
Length of swiveling cross-cut fence	2295 mm (telescopic 3000 mm)

Scoring unit

Diameter scoring blade and bore	120 mm, 20 mm
Cutting depth with 120 mm diameter blade	3,5 mm
Scoring blade rotation speed	8200 RPM
Scoring saw motor power	1,3 kW / 2 hp (S6)

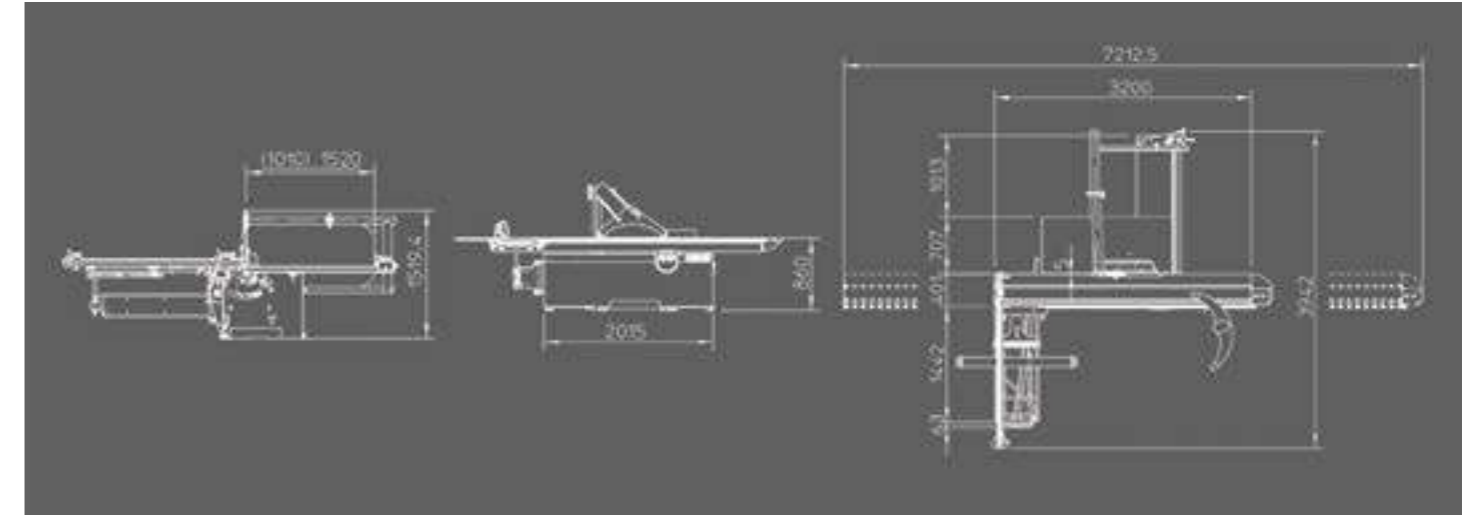

Z500



Z500 with options

Z500 Technical Data

Weight	890 kg (Z500 - 3200) - 1080 kg (Z500 X3 - 3800)
Voltage	400 V 3 phase (option 230 V 3 phase)
Motor power (3 phase)	7 kW / 9,5 hp (S6), option 9,2 kW / 14 hp (S6)
Dust extraction outlets	100 mm in frame + 60 mm on small saw protection (non CE version) 100 mm with overhead saw guard

Saw

Saw blade rotation speed	3000 / 4000 / 5000 RPM
Diameter saw blade and bore	300 - 500 mm, 30 mm
Sawblade tilting	90° - 45°
Cutting depth at 90° / 45°	175 mm / 120 mm
Cutting width parallel fence, version Z500 M, Z500 EL	1350 mm (option 1000 / 1525 mm)
Cutting width parallel fence, version Z500 X1, Z500 X3	1250 (option 1500 mm)
Cutting length	3500 mm (option 2500 mm / 4100 mm)
Dimensions cast iron table	985 mm x 710 mm
Dimensions sliding table	3200 mm (option 2200 mm / 3800 mm) x 420 mm
Dimensions cross-cut table	1505 mm x 760 mm
Length of swiveling cross-cut fence	2295 mm (telescopic 3355 mm)

Scoring unit

Diameter scoring blade and bore	120 mm, 20 mm
Cutting depth with 120 mm diameter blade	3,5 mm
Scoring blade rotation speed	8200 RPM
Scoring saw motor power	1,3 kW / 2 hp (S6)

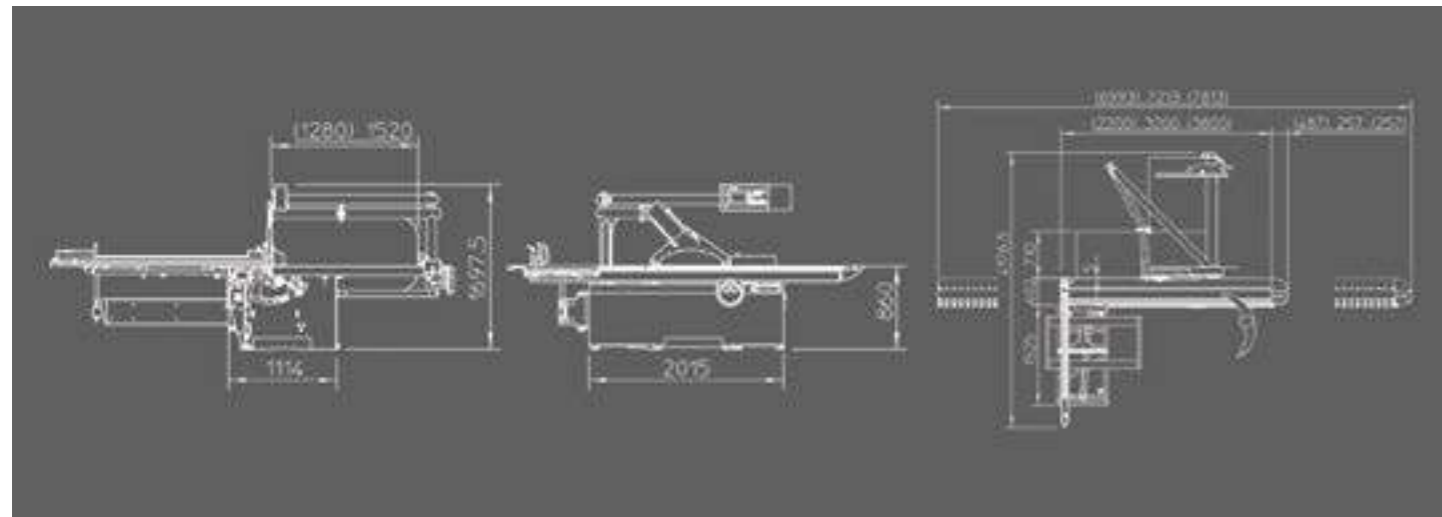

Z SERIES

ROBLAND offers you the choice of different **outrigger tables** on the Z series.

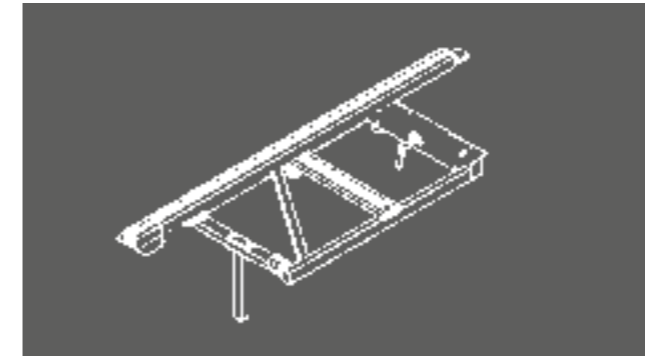

Z300

Basic outrigger table (1000 x 550 mm²) with slanting telescopic cross-cut fence. (1565 - 2550 mm)

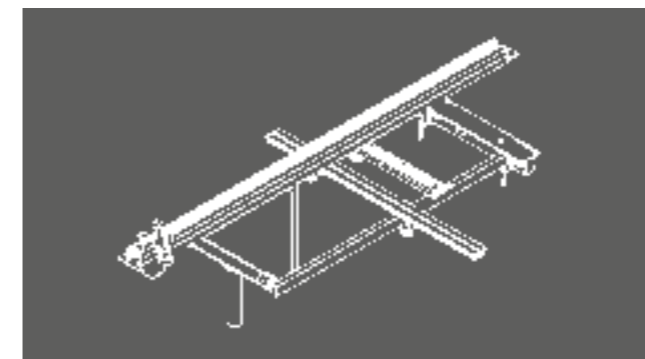

Z400

Large outrigger table (1420 x 650 mm²) with slanting telescopic cross-cut fence (2295 - 3000 mm).

Also available as an option on Z300.

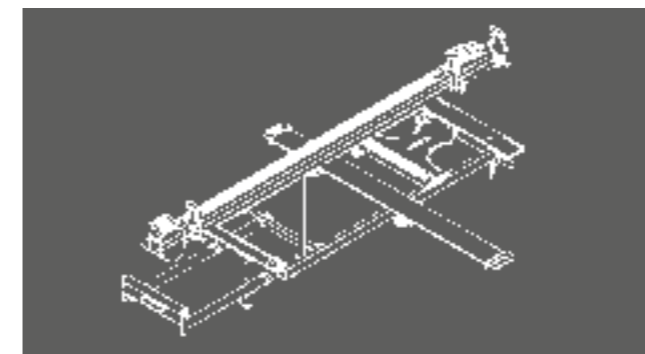

Z400 COMF

Large outrigger table with extension and slanting telescopic cross-cut fence (2295 - 3000 mm). The index system with length correction facilitates accurate sawing of angles and mitre cuts.

Available as an option on Z300 & Z400.

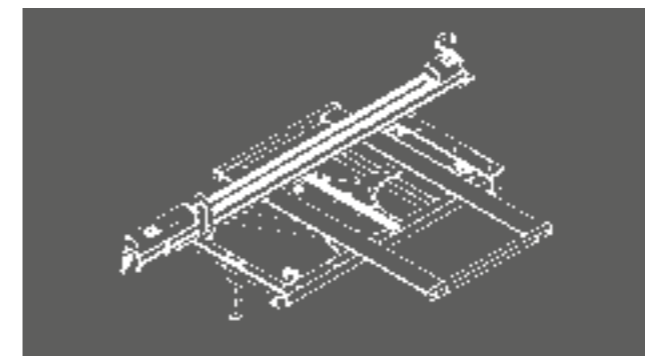

Z500

Luxury outrigger table (1505 x 760 mm²) with extensions in length and width and slanting telescopic cross-cut fence (2295 - 3355 mm). The index system with length correction facilitates accurate sawing of angles and mitre cuts.

Also available as an option on Z400.

OPTIONS



DIGITAL READ-OUT (Z300)

Digital read-out on parallel fence with micro adjustment. This increases the ease of use and accuracy.



DIGITAL READ-OUT (Z400 / Z500)

Digital read-out on parallel fence with micro adjustment. This increases the ease of use and accuracy.

This digital read-out is also available on the Z300 when it is equipped with the optional Z400 parallel fence.



DIGITAL READ-OUTS (Z300 / Z400)

The Double Digital Flippers (DDF) system allows for a digital read-out of the position along the full length of the first part of the outrigger fence. It increases both ease of use and accuracy. The right flipper is used for measurements close to the sawblade while the left flipper allows to measure larger panels.

This digital read-out is also available on the Z300 when it is equipped with the optional Z400 parallel fence. On the Z400 it is possible to have a second digital read-out on the telescopic part.



DIGITAL READ-OUTS (Z500)

Digital read-out on flippers. Increases ease of use and accuracy. Through its large size it allows for continuity from base profile to extension. The telescopic part of the profile also has a digital read-out.



REMOTE START-STOP FUNCTION

Additional start-stop buttons for saw and scoring integrated in the sliding table for increased ease of use and safety.



GROOVE CUTTER

On the Z400 and Z500 a preparation for groove cutter is optionally available.

Ability to cut a groove of max. 16 mm wide.

Z SERIES

ACCESSORIES

Z SERIES



MITRE FENCE

Mitre fence with wood clamp.



Double sided mitre fence.



ADJUSTABLE SCORING BLADE

"LEADER" scoring blade with adjustable width to match the main saw.

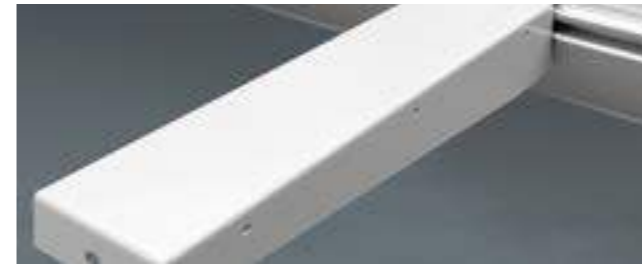

SUPPORT TABLES

Extra support table

Can be positioned anywhere along the aluminium profile of the sliding table. Together with the outrigger table it offers a better support for large panels.

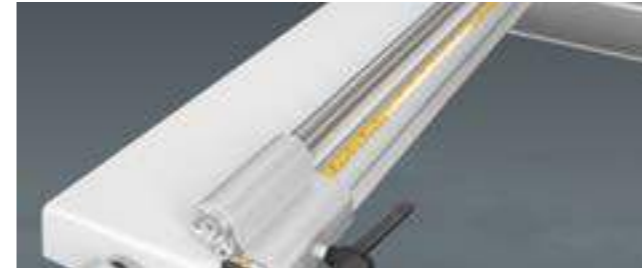

Extra support table with rip fence on ruler for long narrow strips.

Can be positioned anywhere along the aluminium profile of the sliding table. Together with the outrigger table it offers a better support for large panels.

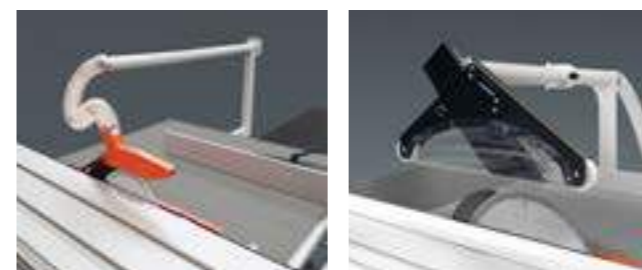

DUST EXTRACTION TUBE AND OVERHANGING SAW GUARD ON Z300 M & Z300 EL

An overhanging dust extraction tube can be mounted on the sawblade protection. It offers a standard dust extraction outlet of 100 mm.

For optimal safety and dust extraction, the overhanging saw guard mechanically adjusts to the height of the workpiece. The arm is easy to turn away.

PANEL SAWS

OVERVIEW

SCE = Standard on CE-version (optional on non-CE) / S = Standard / X = Present / O = Optional

	NXZ	E300	E2500	Z300M	Z300EL	Z300X1	Z300X3	Z400M	Z400EL	Z400X1	Z400X3	Z500M	Z500EL	Z500X1	Z500X3
Machine basics															
Manual	X	X	X	X	-	-	-	X	-	-	-	X	-	-	-
Electrical height and tilt	-	-	-	-	X	X	-	-	X	X	-	-	X	X	-
1 Axis controll (parallel fence)	-	-	-	-	-	X	-	-	-	X	-	-	-	X	-
3 Axis controll (parallel fence + height + tilt)	-	-	-	-	-	-	X	-	-	-	X	-	-	-	X
Motor powers (S6)															
single phase 2 kW	O	O	-	-	-	-	-	-	-	-	-	-	-	-	-
single phase 3 kW	-	-	O	O	-	-	-	O	-	-	-	-	-	-	-
3,7 KW - 3 * 380 V	S	S	-	-	-	-	-	-	-	-	-	-	-	-	-
3,7 KW - 3 * 220 V	O	O	-	-	-	-	-	-	-	-	-	-	-	-	-
4,4 KW - 3 * 380 V	-	-	S	S	S	S	S	-	-	-	-	-	-	-	-
4,4 KW - 3 * 220 V	-	-	O	O	O	O	O	-	-	-	-	-	-	-	-
7 KW - 3 * 380 V	-	-	-	O	O	O	O	S	S	S	S	S	S	S	S
7 KW - 3 * 220 V	-	-	-	O	O	O	O	O	O	O	O	O	O	O	O
9,2 KW - 3 * 380 V	-	-	-	-	-	-	-	O	O	O	O	O	O	O	O
9,2KW - 3 * 220 V	-	-	-	-	-	-	-	O	O	O	O	O	O	O	O
Saw aggregate max. diameter															
250 mm	O	-	-	-	-	-	-	-	-	-	-	-	-	-	-
300 mm	-	S	S	-	-	-	-	-	-	-	-	-	-	-	-
315 mm	S	-	-	S	S	-	-	-	-	-	-	-	-	-	-
400 mm	-	-	-	-	-	-	-	S	S	S	S	-	-	-	-
500 mm	-	-	-	-	-	-	-	-	-	-	-	S	S	S	S
Scoring unit															
	O	S	S	S	S	S	S	S	S	S	S	S	S	S	S
Speeds on saw															
4000 RPM	-	-	-	S	S	S	S	-	-	-	-	-	-	-	-
4500 RPM	S	S	S	-	-	-	-	O	O	O	O	O	O	O	O
3000 / 4000 / 5000 RPM	-	-	-	O	O	O	O	S	S	S	S	S	S	S	S
Cutting length															
1600 mm	S	-	-	-	-	-	-	-	-	-	-	-	-	-	-
1700 mm	-	S	-	-	-	-	-	-	-	-	-	-	-	-	-
2000 mm	O	-	-	-	-	-	-	-	-	-	-	-	-	-	-
2500 mm	O	-	S	O	O	O	O	O	O	O	O	O	O	O	O
2800 mm	-	-	O	-	-	-	-	-	-	-	-	-	-	-	-
3100 mm	-	-	O	O	O	O	O	-	-	-	-	-	-	-	-
3500 mm	-	-	-	S	S	S	S	S	S	S	S	S	S	S	S
4100 mm	-	-	-	O	O	O	O	O	O	O	O	O	O	O	O
Cutting width parallel fence															
700 mm	-	-	-	O	O	O	O	-	-	-	-	-	-	-	-
900 mm	S	-	-	-	-	-	-	-	-	-	-	-	-	-	-
1000 mm	-	-	-	O	O	-	-	O	O	-	-	O	O	-	-
1250 mm	O	S	S	S	S	S	S	-	-	S	S	-	-	S	S
1350 mm	-	-	-	O	O	O	O	S	S	-	-	S	S	-	-
1500 mm	-	-	-	-	-	-	-	O	O	O	O	O	O	O	O
Digital readout															
Outtrigger table	-	-	O	O	O	O	O	O	O	O	O	O	O	O	O
Parallel fence	-	-	O	O	O	S	S	O	O	S	S	O	O	S	S
Overhead saw guard															
	-	O	O	O	O	S	S	SCE	SCE	S	S	SCE	SCE	S	S
Remote control in sliding table															
	-	-	-	O	O	O	O	O	O	O	O	O	O	O	O

PANEL SAWS



NXZ



E300



E2500

SPINDLE - MOULDERS



T120S



T120L



T120P



Z300 SERIES



Z400 SERIES



Z500 SERIES



T110i

TABLE SAW



M500

COMBINED MACHINES



HX260

PLANER - THICKNESSERS



NXSD310



NXSD410



SD410



HX310 PRO



NX310/410 PRO



NLX310/410 PRO

PLANERS



SD510



S410



J510



NXTZ PRO



NLXTZ PRO

DRILLING MACHINES



BM21 PRO

THICKNESSERS



D510



D630

HORIZONTAL SLOT MORTISER



LBM



BM3000

EDGEBANDERS



ALPHA



KM575



This brochure is for information purposes only. Robland reserves the right to modify machine configurations and specifications without prior notice. Standard configurations can change over time and by point of purchase. Please consult your local dealer for accurate and up to date information.

Robland NV
Kolvestraat 44
8000 Brugge - Belgium
Tel: +32 50 458 925
info@robland.com
www.robland.com



Follow us on Facebook
www.facebook.com/Roblandmachines



Follow us on Instagram
www.instagram.com/robland_nv



Follow us on YouTube
www.youtube.com/robland