

Perfect for assembly.

HE HOMAG

Case clamps

CABTEQ S-200, S-250, T-200

YOUR SOLUTION





An elegant design, perfect for assembly.

Whether they are used in furniture production, furniture building and shop fitting, or custom industrial production, the presses have impressive versatility. From one simple case clamp to a customized assembly line, we have a solution to meet your final assembly needs.

YOUR SOLUTION

MORE: HOMAG.COM



Case clamps
CABTEQ

CONTENTS

- 04 YOUR SOLUTION
- 06 CABTEQ S-200
- 08 CABTEQ S-250
- 10 CABTEQ T-200
- 12 LifeCycleServices
- 14 Technical data



YOUR SOLUTION. For cleanly pressed furniture.

As the last step in production before packaging and delivery, the assembly quality has a significant impact on the end customer's satisfaction with the product. Whether it's a one-of-a-kind design, made-to-measure manufacturing or series production: When it comes to building kitchens, manufacturing bathrooms or producing office furniture, cleanly pressed cabinets are a key sign of quality in pre-assembled furniture. The HOMAG assembly technology product series offers the right solutions for smart final assembly.

Every case clamp has three things in common: reliability, high levels of performance and pressing quality. From the stationary case clamp to the throughfeed case clamp, the pressing force is conveyed to the cabinet according to the individual material properties. This ensures tightly pressed cabinets with the benefits of accurate square alignment. The combination of ergonomics and power creates real benefits during final assembly, including ever-increasing assembly quantity and quality and a reduced workload for employees.



"The high level of workmanship of the furniture ensures a significant competitive advantage. A press always applies even pressure to the cabinet, meaning that the joints of the cabinet are always tight and perpendicular. This also makes the operator's job easier, as each function the machine completes is one less task for the humans."

Alexander Runge — Technical Sales, Systems



HC

CABTEQ S-200

CABTEQ S-200

Solid technology at a low price.

The CABTEQ S-200 is the ideal assembly aid for pressing cabinet furniture. The practice-oriented machine design reduces the space requirement of the case clamp to a minimum. Thanks to its intuitive operation, cleanly pressed, sealed cabinets with the benefits of accurate square alignment can be achieved at the touch of a button.

CABTEQ S-200 — perfect for pressing cabinet furniture.

- The CABTEQ has two speeds: an approach speed (rapid speed) and a pressing speed.
- At the touch of a button, the plates move from their starting position to the pressing position at rapid speed just before hitting the cabinet. The speed then switches to pressing speed.
- This rapid speed allows for more cabinets to be pressed per shift.
- Depending on the cabinet type, the pressing force can be adjusted to different requirements at the touch of a button.
- Each cabinet is pressed centrally and over the entire surface.

HOW OUR CUSTOMERS CAN BENEFIT

- **High level of assembly quality**
Fully sealed, cleanly pressed cabinets that are accurately and squarely aligned
- **Intuitive operation**
No prior knowledge required
- **Low space requirements**
Fits in any workshop
- **Plug and play**
Install, connect and begin



Intuitive operation: Operation is simple and requires no prior knowledge — simply place the cabinet in the press and then press the start button to begin the pressing process. Install, connect and begin.



Press surfaces with tolerance compensation: The press plates function as a unit and sit on rubber feet, which provide cushioning. When the plates simultaneously reach the cabinet, the pressure is distributed completely evenly. This ensures that tolerances in the cabinet are better absorbed.



Sliding pre-plugging station: The pre-plugging station allows a simple assembly of the carcasses at working height of the press.



Manual cabinet uprigger: The cabinet uprigger is used for the uprighting and onward transport of assembled cabinets.



Operating the cabinet uprigger: By simply pulling on the lever, the cabinet uprigger aligns the pressed cabinet.

CABTEQ S-250

Power and ergonomics combine for challenging cabinet assemblies

The CABTEQ S-250 is highly versatile, with applications in the small trade sector, interior design and custom industrial production. Enhanced by an ergonomic environment, with features such as the sliding pre-plugging station and the manual cabinet uprighter, assembly is more efficient, performance can be increased and the workload of staff is markedly reduced.

CABTEQ S-250 – pressing force meets ergonomics.

- The CABTEQ has two speeds: an approach speed (rapid speed) and a pressing speed.
- At the touch of a button, the plates move from their starting position to the pressing position at rapid speed just before hitting the cabinet. The speed then switches to pressing speed.
- This rapid speed allows for more cabinets to be pressed per shift.
- Depending on the cabinet type, the pressing force can be adjusted to different requirements at the touch of a button.
- Each cabinet is pressed centrally and over the entire surface.



Press surfaces with tolerance compensation: The press plates function as a unit and sit on rubber feet, which provide cushioning. When the plates simultaneously reach the cabinet, the pressure is distributed completely evenly.

HOW OUR CUSTOMERS CAN BENEFIT

- **High level of assembly quality**
Fully sealed, cleanly pressed cabinets that are accurately and squarely aligned
- **Intuitive operation**
No prior knowledge required
- **Low space requirements**
Fits in any workshop
- **Plug and play**
Install, connect and begin
- **Ergonomic environment**
Ergonomic aids (optional) simplify the assembly process



Intuitive operation: Operation is simple and requires no prior knowledge. The cabinet is simply placed in the press before the start button is pushed. The pressing process then begins. Install, connect and begin.

CABTEQ T-200 — fully sealed cabinets from series to batch size 1 production.

- Precisely adjustable pressing force allows cabinets with delicate surfaces, thin walls and small cabinets to be pressed.
- The key length and height dimensions are scanned when the cabinet is fed in, which enables the top roll pressure unit and the lateral pressure elements to be positioned automatically.
- Pressing is carried out centrally at the zero line on the operator side, meaning that the cabinet can always be freely accessed by the operator.
- Precise ball screw drives with servo technology ensure accurate and fully automatic adjustment to different production parameters.
- Electrical rather than pneumatic counterbalancing of the press top roll pressure unit enables energy savings of up to 50 percent.



CABTEQ T-200

Flexible technology for a range of cabinets

Even for delicate or thin-walled cabinets, high-quality or miter furniture — the electric throughfeed case clamp CABTEQ T-200 automatically presses every cabinet gently and with a high level of quality. The result is perfectly right-angled, stable and cleanly pressed cabinets. The electric throughfeed case

clamp is ideally suited for use as an individual machine or in production lines, in series production, small-batch production and batch size 1 production. Ergonomic aids (optional) also simplify the assembly process.



Lateral clamping plates: The clamping plates work as a unit. The pressing forces are generated electrically and can be adjusted individually. Pressure is applied vertically by a pressure plate and horizontally by the three clamping plates.



Ease of use: Operation is easy and intuitive. Built-in help and assistant functions make work more straightforward. Settings such as pressing time and pressing pressure can be entered quickly and easily by the operator via a touch monitor.

HC LIFE CYCLE SERVICES

Optimal service and individual consultations are included in the purchase of our machines. We support you with service innovations and products which are especially tailored to your requirements. With short response times and fast

customer solutions we guarantee consistently high availability and economical production – over the entire life cycle of your machine.



REMOTE SERVICE

- Hotline support via remote diagnosis by our trained experts regarding control, mechanics and process technology. Thus, more than 90% less on-site service required and consequently a faster solution for you!
- The ServiceBoard App helps to solve tasks in a fast, simple and concrete way. This is achieved by mobile live video diagnosis, automatic sending of service requests or the online spare parts catalog eParts.



SPARE PARTS SERVICE

- High spare parts availability and fast delivery.
- Ensuring quality by predefined spare parts and wear parts kits, comprising original spare parts.
- Identify and inquire for spare parts online under www.eParts.de 24/7, or buy even faster and more comfortably in the new HOMAG Webshop eCommerce.



MODERNIZATION

- Keep your machinery up to date and increase your productivity as well as your product quality, This is how you can meet tomorrow's requirements today!
- We support you with upgrades, modernization as well as individual consultancy and developments.



DIGITAL SERVICES

- ISN (intelliServiceNet) – The new remote service solution of the future! Fast restart of production because the remote service employee has extensive access to relevant physical data.
- intelliAdvice App – provides help for self-help. The preventive solutions proposed in the new App are the combination of our experiences and existing machine data.

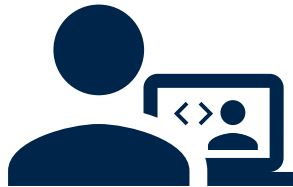

SOFTWARE

- Telephone support and consultancy through software support.
- Digitalization of your spare parts via 3D scanning saves time and money compared to new programming.
- Subsequent networking of your machinery with intelligent software solutions ranging from construction to production.



FIELD SERVICE

- Increased machine availability and product quality by certified service staff.
- Regular checks through maintenance / inspection guarantee the highest quality of your products.
- We offer you the highest availability of technicians in order to reduce downtimes in case of unpredictable troubles.

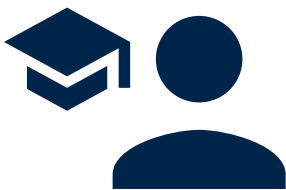

TRAINING

- Thanks to training perfectly suited to your requirements, your machine operators can optimally operate and maintain the HOMAG machines.
- The training also include customer-specific training documents with exercises proven in practice.
- Online training and webinars. Learn without traveling, meet your trainer in the digital classroom.

For you more than ...

1,350

service employees worldwide

90%

less on-site service thanks to
successful remote diagnosis

5,000

customer training sessions per / year

150,000

machines, all electronically documented
in 28 different languages – in eParts

TECHNICAL DATA	CABTEQ S-200	CABTEQ S-250	CABTEQ T-200
Cabinet dimensions			
Cabinet length	150 – 2,500 mm	150 – 2,500 mm (3,000 mm)	250 – 2,500 mm (3,100 mm)
Cabinet width	250 – 700 mm	250 – 700 mm (900 mm)	120 – 800 mm (1,000 mm)
Cabinet height	150 – 1,400 mm	150 – 1,400 mm	220 – 1,320 mm
Pressing pressure			
vertical	max. 12 – 18 kN	max. 12 – 18 kN	max. 30 kN
horizontal	max. 12 – 18 kN	max. 12 – 18 kN	max. 15 kN

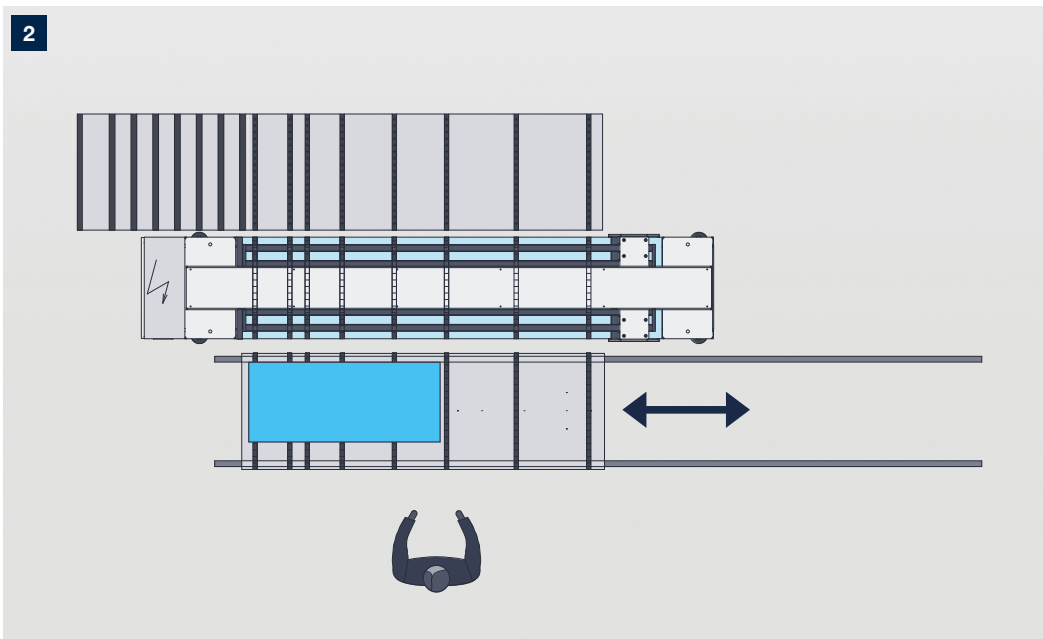
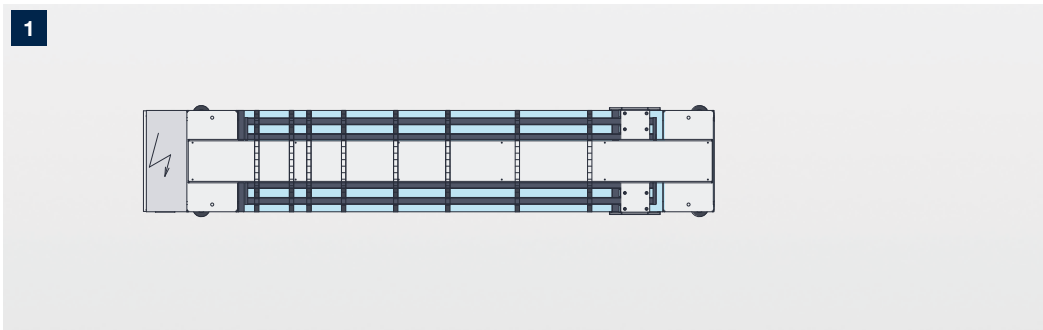

1 CABTEQ S-200

- Solid technology at a low price

2 CABTEQ S-250

- Power and ergonomics for challenging cabinet assemblies

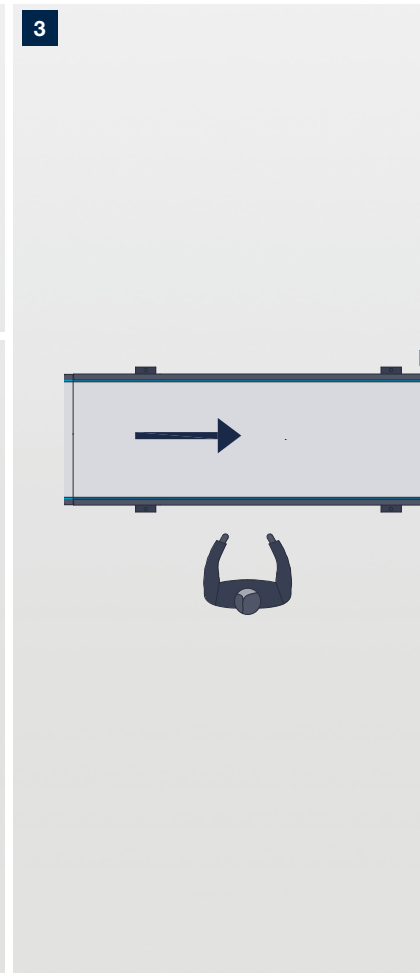

3 CABTEQ T-200

- Flexible technology for a range of cabinets

TECHNICAL DATA	CABTEQ S-200	CABTEQ S-250	CABTEQ T-200
Processing height	300 mm	300 mm	500 mm
Weight	Approx. 2.2 t	Approx. 2.2 t	5.0 – 6.0 t
Positioning speed			
Rapid speed	50 mm/s	50 mm/s	-
Slow speed	25 mm/s	25 mm/s	-
Transports feed	-	-	12 – 40 m/min
Operating pressure	-	6 bar	6 bar

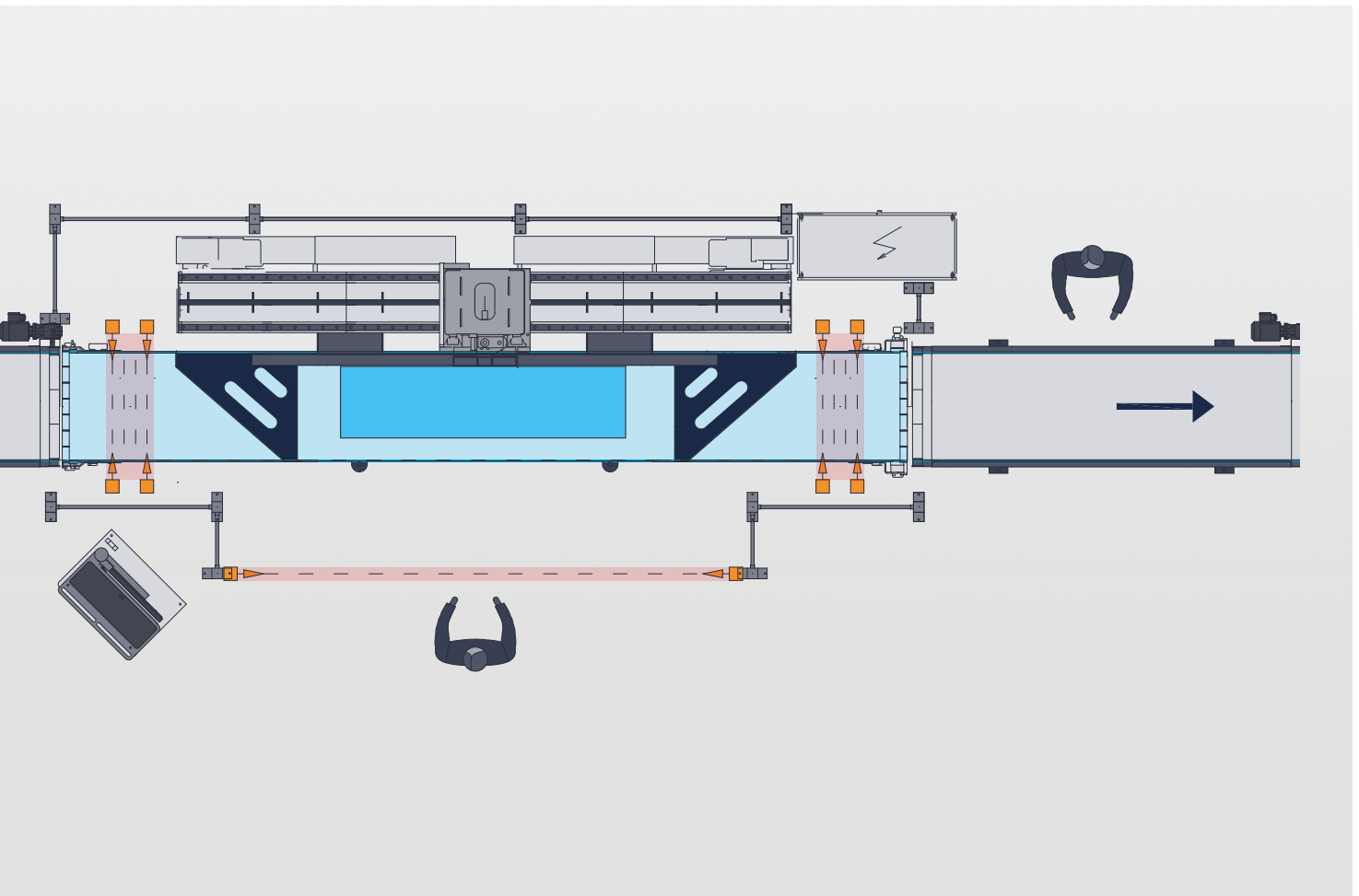

MORE: HOMAG.COM



Case clamps
CABTEQ

HOMAG Group AG

info@homag.com

www.homag.com



YOUR SOLUTION