



MY NEW WA80.

FEATURES, OPTIONS.



ALTENDORF GROUP



Two models, one promise: Performance, you can count on.



WA80TE → Page 4

Altendorf WA80TE with motorised rise/fall and tilt adjustment of the main saw blade.



WA80 X → Page 6

Altendorf WA80 X with motorised rise/fall and tilt adjustment of the main saw blade and motorised adjustment of the rip fence.



The Altendorf WA 80: Quality made in Germany.



■ **The Altendorf WA 80** can take on any cutting challenge you can present it with, whatever material you want to cut, whether wood or plastic. With its well thought out design and robust build quality, it makes light work of simple but precise squaring cuts through to complex angles. Completely designed, developed and assembled in Germany, the machine sets a new benchmark for sliding table saws in terms of price and quality. The Altendorf WA 80 is a pleasure to work with, cut for cut, day after day.



The Altendorf WA 80 is assembled in a factory with the most up-to-date production machinery and methodology under the strictest quality control in Minden, Germany.

**BASIC SPECIFICATION FOR THE WA 80 TE:**

Motorised rise/fall 0–46° and tilt adjustment of the main saw blade

Sliding table, table length 3000mm

Rip fence, manual adjustment using graduated scale,
includes fine adjustment, cutting width 1000 mm

Crosscut fence with fixed 90° angle,
manual adjustment using graduated scale up to 3200 mm

Maximum saw blade protrusion 150 mm,
maximum saw blade diameter 450 mm

Motor rating 4 kW (5.5 HP), single speed (4000 rpm)

AKE tool clamping system for the main saw blade

Ergonomic controls: With the Altendorf WA 80 TE the height and angle of the blade are simply adjusted at the press of a button. The digital display of the angle remains in your field of vision at all times during the cutting operation.



Accurate: The Altendorf WA 80 TE with motorised rise/fall and tilt adjustment of the main saw blade.



■ **Machine frame control panel:** All functions are easily accessed on the control panel on the machine frame. You can control the rise/fall and tilt of the main saw blade at the touch of a button. The tilt angle is shown on the digital display.



■ **Saw blade protrusion:** The WA 80 saw blade protrusion is 150 mm (saw blade diameter 450 mm). This results in a greater cutting height when crosscutting or square cutting and also when angle cutting with the saw blade tilted.



■ **Rip fence with manual fine adjustment:** Setting the fence is easy; the precision fine adjustment makes for great accuracy. The hard chrome-plated round bar system ensures the fence moves smoothly. The rip fence drops down clear of the machine table level to free up extra space for dividing large panels. Available cutting widths: 800 mm, 1000 mm or 1300 mm.

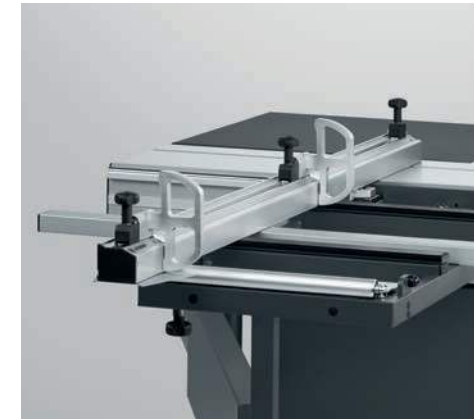

■ **Crosscut fence with fixed 90° angle:** The crosscut fence with fixed 90° angle earns its corn every day helping out with precision cuts on workpieces of different lengths and formats. The stop can be slid into place easily without lifting. Two flip stops are included. The basic specification includes stops to 3200 mm, adjustable using the graduated scale.



6

ALTENDORF WA 80 X



BASIC SPECIFICATION FOR THE WA 80 X:

Motorised rise/fall 0–46° and tilt adjustment of the main saw blade

Eye-level operating panel

Sliding table, table length 3000mm

CNC rip fence, cutting width 1000mm

Crosscut fence with fixed 90° angle,

manual adjustment using graduated scale up to 3200mm

Maximum saw blade protrusion 150mm,

maximum saw blade diameter 450mm

Motor rating 4kW (5.5HP), single speed (4000rpm)

AKE tool clamping system for the main saw blade

*Number one for ease of operation and ergonomics.
The eye level control panel of the Altendorf WA80X
can be pivoted to the most convenient position for
the operator.*



Ergonomic: The Altendorf WA 80 X with three motorised axes.



■ **Eye-level operating panel:** All major control functions are always visible. The panel pivots into the most convenient position and is accessible from both sides of the machine. Adjustment of both the saw blade and the rip fence are motorised.



■ **Saw blade protrusion:** The WA80 saw blade protrusion is 150 mm (saw blade diameter 450 mm). This results in a greater cutting height when crosscutting or square cutting and also when angle cutting with the saw blade tilted.

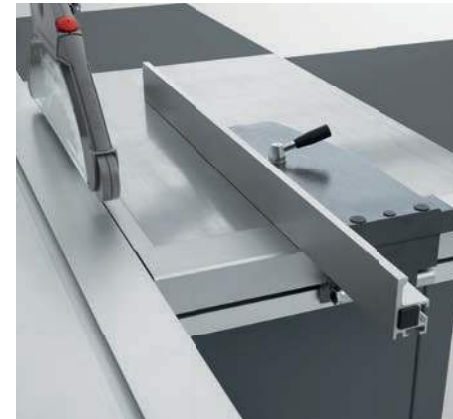

■ **CNC rip fence:** The CNC rip fence has a traverse speed of 200 mm/sec. and an accuracy of $\pm 1/10$ mm. The high precision five-point recirculating ball spindle system needs little maintenance and, along with the motor, is well protected by its integration into the aluminium profile. The fence detects its position automatically, especially in the danger area around the saw blade, and has an emergency cut-out to prevent the risk of crushing. Dimensions are corrected automatically when the fence is switched between the upright and the flat position or when working with the saw blade tilted. Available cutting widths: 800 mm, 1000 mm or 1300 mm.

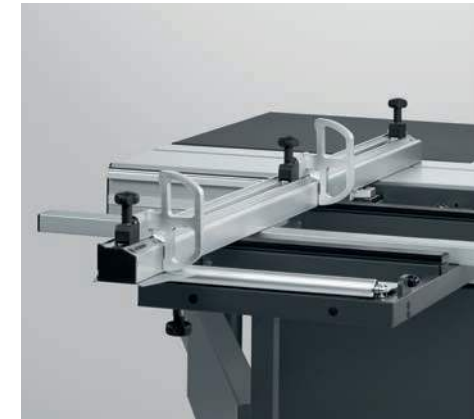

■ **Crosscut fence with fixed 90° angle:** The crosscut fence with fixed 90° angle earns its corn every day helping out with precision cuts on workpieces of different lengths and formats. The stop can be slid into place easily without lifting. Two flip stops are included. The basic specification includes stops to 3200 mm, adjustable using the graduated scale.



Full performance to the last detail.



■ **Altendorf saw unit:** Smooth-running and powerful. The Altendorf saw unit is the engineering heart of all our saws. It is a powerhouse produced with the latest manufacturing technology. The saw shaft runs incredibly smoothly: this is because it is electronically balanced as a fully assembled unit, and extensive use is made of cast components. The high-precision vertical movement of the unit is linear with maintenance-free guide bearings. The robust tilt quadrants incorporate the traditional Altendorf tongue and groove connection system, which allows the whole unit to tilt easily and precisely to exactly the correct angle. The basic specification includes a 4 kW (5.5 HP) main motor with one sawshaft speed.

A 5.5 kW (7.5 HP) or a 7.5 kW (10 HP) motor are available as options with three speeds 3/4/5 000 rpm.



■ **On/off switches on sliding table:** The practical option. The on/off switches are always right where you need them, at the end of the sliding table. The four keys switch both the main and scoring blades on and off. This option allows you to load a large workpiece before switching the machine on, thus improving safety and convenience. The keys can be operated without you having to switch specially between the machine operating panel and the sliding table switches.

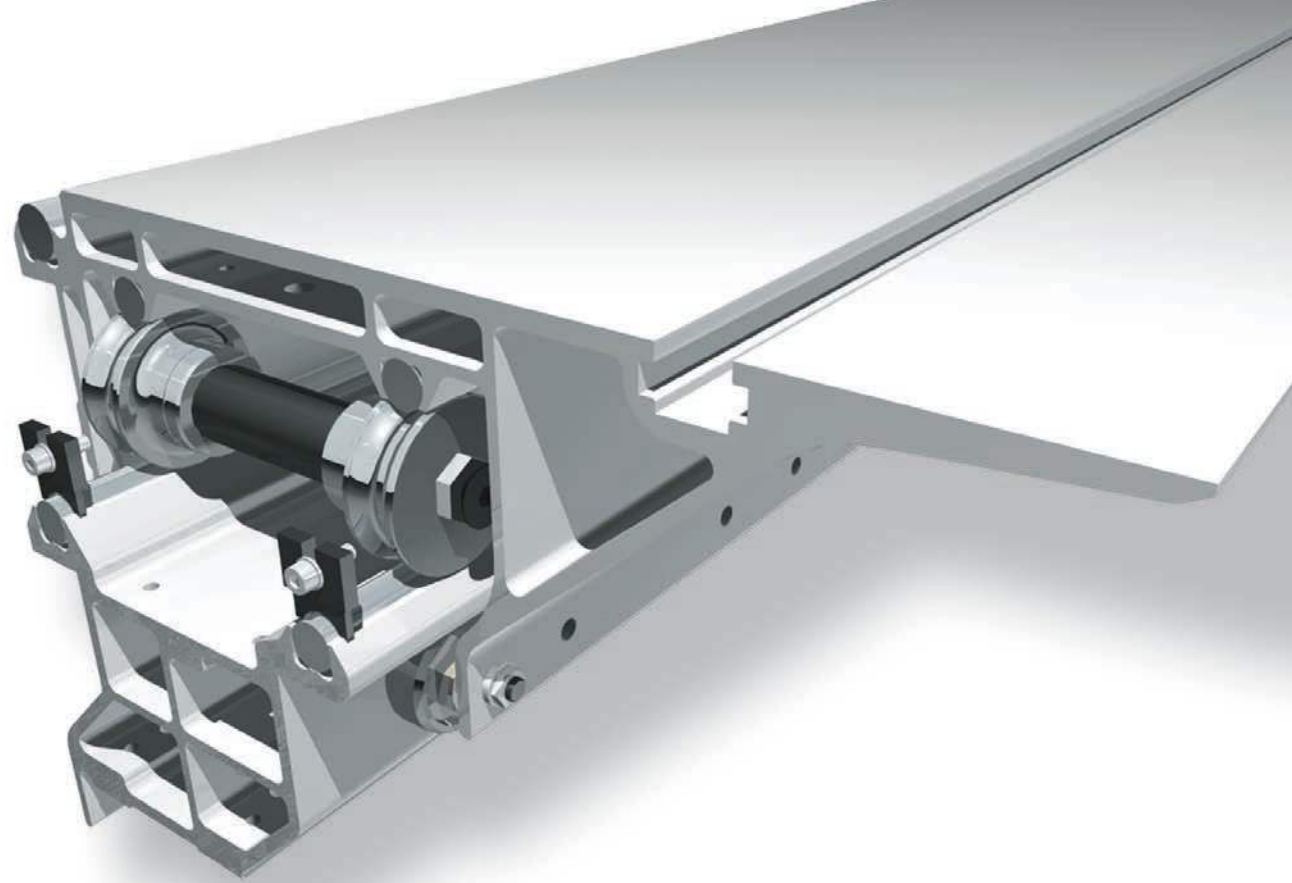

■ **Sliding table:** The Altendorf sliding table is renowned for its smooth and exact running. This is one of the hallmarks of an Altendorf, and it all comes down to design: the table runs on large dumbbell rollers sandwiched between hard chromed guide bars, guaranteeing absolute precision. The system's large rollers ensure smooth action, meaning the table takes less effort to move and glides as securely as if it were on rails. This quality running will endure decades of heavy load bearing in the constant presence of dust and chips, and it needs virtually no maintenance. Each time the table moves, the brush fitted to the upper part automatically cleans the round guide bars. The system operates without any lubrication. The table's hollow multi-chamber aluminium extrusion guarantees optimal torsion resistance and rigidity.



Made to measure performance: The options.



■ **Scoring unit with motorised adjustment:** The scorer prevents chipping out on the underside of laminated panels. The rise and fall is motorised, the lateral adjustment manual. When the scoring blade is switched on, the scorer moves to the height stored. When either the main or scoring blade is switched off, the scorer moves back under the table. The scorer has an independent 0.75kW (1 HP) motor and turns at 8200rpm.



■ **RAPIDO scoring tool:** The RAPIDO scoring system makes it easier and quicker to adjust the cutting width to match that of the main blade. How quick? About three minutes, max! Compared to working with shims, where you have to take the blade off the machine to alter its width, the RAPIDO saves at least ten minutes, as the blade stays on the machine during adjustment. Adjustment is continuous so the RAPIDO can be fine-tuned to match any main blade. Adjustment range: 3.2–3.8mm, $\varnothing = 120$ mm.



■ **LED illumination:** Particularly energy-efficient LEDs render the danger area around the scorer highly visible.



■ **Rip fence with DIGIT X:** A digital cutting width display for the rip fence with manual fine adjustment. This electronic measuring system guarantees rapid, precise adjustment of the rip fence. Recurring dimensions can be reproduced exactly and checked on the DIGIT X display. The correction for the rip fence position is shown digitally on the machine control unit's display when working with the saw blade tilted. The system is not subject to wear and is unaffected by dust. Dimensions are corrected automatically when the fence is switched between the upright and the flat position. Available cutting widths: 800mm, 1 000mm or 1 300mm.



■ **Crosscut fence with DIGIT L:** For 1/10 mm accuracy when setting the length dimension. The display shows all stop settings at the same time, and allows calibration of all stops in one operation. Two flip stops with fine adjustment, two batteries and a charger are included.



■ **Crosscut-mitre fence:** This patented Altendorf fence, with integral length compensation, makes it easier to perform bevel cuts and mitre cuts precisely in one function. The set angle can be adjusted continuously over a range of 49° with a graduated scale and the robust, free-sliding zero-play flip stops can be positioned individually at any distance up to a maximum of 3 500 mm. The outer stop docks into the roller-stabilised telescopic extension for distances longer than about 1 700 mm. The integral length compensation feature enables the fence to be moved precisely to any required position when cutting mitres with no need of additional length compensation aids.



■ **Crosscut-mitre fence with DIGIT L or DIGIT LD:** For 1/10 mm accuracy when setting the length dimension. The display shows all stop settings applied. The central measuring and display unit calibrates the entire system in one operation. Two flip stops with fine adjustment, two batteries and a charger are included.

The DIGIT LD also displays the angle digitally, enabling a level of precision of $\pm 1/100^\circ$. The length dimension is calculated automatically as a function of the mitre angle. Two flip stops with fine adjustment, three batteries and a charger are included.



■ **One-sided mitre fence:** The one-sided mitre fence enables precise cutting of mitres. It is easy to set and can be positioned on the sliding table with the minimum of effort.



Made to measure performance: The options.



■ **DUPLEX double-sided mitre fence:** DUPLEX fences make it possible to cut any angle between 0 and 90° very quickly and exactly. Set the DUPLEX to 45° and a mitre cut can be made on both sides of the workpiece without resetting the two fences. Dimensions are set using a magnifier, a measuring scale and a length compensation scale. All DUPLEX fences can be positioned anywhere along the entire length of the sliding table.

It is also available as DUPLEX D, with a digital display of the angles which calculates the values to an accuracy of 1/100°. Stops to 1350 mm or 2150 mm.



■ **DUPLEX DD:** An exclusive Altendorf development, the DUPLEX DD has been patented worldwide. The high precision DUPLEX DD electronics incorporate automatic length compensation and calculate the distance to the stops as a function of the angle on both sides of the fence and display both figures digitally. Digital angle display and digital length display for adjustment, automatic length compensation. Batteries included. Stops to 1350 mm or 2150 mm.

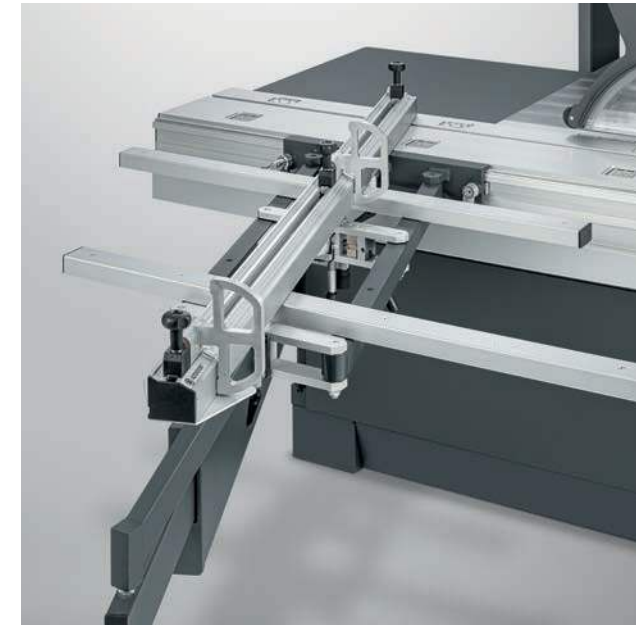

■ **Parallelogram cross slide (PQS):** Changing was yesterday! The fence rule arranged in the centre allows the workpiece to be positioned at the front and the rear. The two adjustable supports ensure secure support here. Not only is this unique, it is also quick and easy. Features a robust 90° locking mechanism that ensures the right-angle position is absolutely reproducible. The fence can be angled by up to 47° in either direction. The integrated digital display shows the set angle with an accuracy of 1/100° for optimal precision. Also included is length compensation, which is simply taken from a scale when the fence is angled. Two flip stops are included.



■ **Parallelogram cross slide with DIGIT LD:** for 1/10 mm accuracy when setting the length dimension. The display shows all stop settings applied. The central measuring and display unit calibrates the entire system in one operation and angles are displayed in digital format, enabling a level of precision of $\pm 1/100^\circ$. The length dimension is calculated automatically as a function of the mitre angle. Two flip stops with fine adjustment, three batteries and a charger are included.



■ **Laser cutting line marker:** The laser cutting line marker shows the cutting line clearly for all cut lengths, which is useful when trimming or cutting marked jobs such as steps. Use it to save both time and materials.

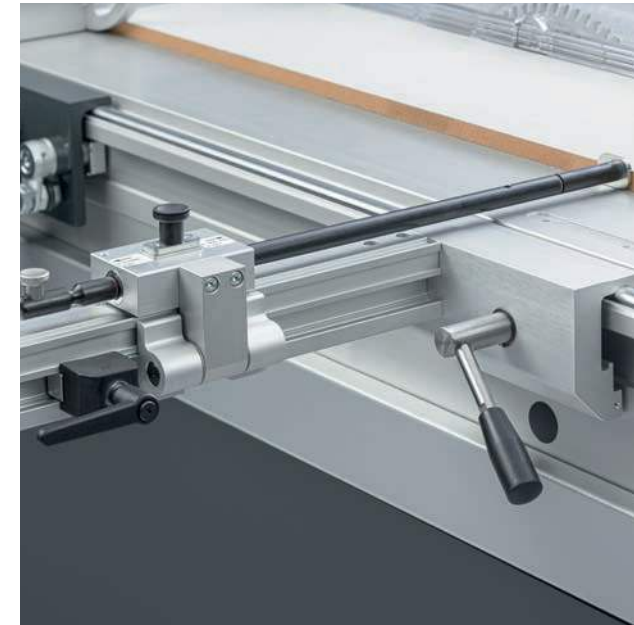

■ **PALIN:** Used in combination with the crosscut fence, the PALIN allows you to cut parallel and conical workpieces on the sliding table. By butting against the side of the workpiece, differing lengths can be cut quickly and precisely without having to move the PALIN. One other benefit: By folding the measuring system away the PALIN also serves as an additional workpiece support. Also available is the PALIN D model, which offers digital measurement display and fine adjustment. Adjustment range 80–950 mm.



Made to measure performance: The options.



■ **Manual quick-action clamp:** The alternative to the pneumatic clamp. The manual clamp can be easily positioned on the sliding table and fixed. The workpiece is then firmly secured on the table and the crosscut fence. It has a clamping height of up to 200 mm and provides extra safety at very little extra cost. Not available in CE region.



■ **STEG:** Enlarges support area (width: 400 mm) for wider workpieces. Makes it much easier to size large panels.



■ **Front support roller:** The 300 mm-wide infeed support roller is particularly useful when cutting longer workpieces against the rip fence. It folds away under the sliding table (minimum length 3000 mm) when not required.





SLIDING TABLE CUTTING LENGTHS

Maximum cutting lengths when using clamping shoe or crosscut fence

Table length (mm)	2250	3000	3200	3400	3800	4300
Cutting length (mm)	2150	2900	3100	3300	3700	4010
Cutting length (mm) with PQS	1880	2630	2830	3030	3430	3740

MAXIMUM SAW BLADE PROTRUSION

With or without scoring saw blade

Saw blade diameter (mm)	250	300	315	350	400	450*
Saw blade protrusion 90° (mm)	0-50	0-75	0-82	0-100	0-125	13-150
Saw blade protrusion 45° (mm)	0-33	0-50	0-56	0-70	0-87	6-103

*the scoring saw blade must be removed.

CUTTING WIDTHS 800, 1000, 1300 mm

MACHINE WEIGHT starting at 1000 kg

TABLE HEIGHT 910 mm

ELECTRICAL POWER REQUIREMENTS ¹⁾

Motor (kW)	4	5.5	7.5
Voltage (V)	380-420	380-420	380-420
Frequency (Hz)	50	50	50
Current (A) without/with scorer	7.5/9.5	11.5/13.5	15.5/17.5
Fuses/circuit breakers (A)	25	25	25

DUST EXTRACTION CONNECTIONS

Top connection:	Ø = 80 mm
Bottom connection:	Ø = 120 mm
Pressure drop:	1200 Pa with a total connection diameter, Ø = 140 mm
Minimum air requirement:	V _{min} = 1110 m³/h at 20 m/sec.

¹⁾The cross section of the mains cable depends on the machine's distance from the power source and must be determined by a qualified electrician (Power drop in the input cable ≤ 3%). Please contact your Altendorf sales partner if your power supply does not match the requirements shown. Workstation noise level 85.2 dB (A).

Tecnical specifications.

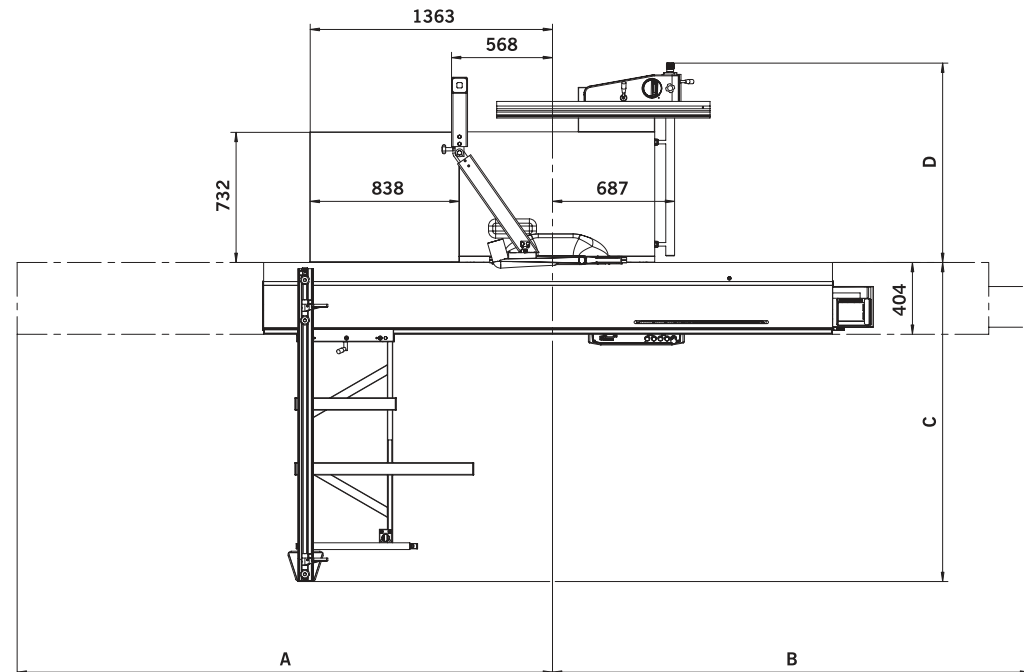

SPACE REQUIREMENTS

- A Sliding table length + 290 mm
- B Sliding table length + 360 mm
- C Crosscut fence, stops to 2500 mm: 1500-max. 2630 mm
Crosscut fence, stops to 3200 mm: 1890-max. 3420 mm
Crosscut-mitre fence, stops to 3500 mm: 1960-max. 3690 mm
- D Cutting width + 310 mm



All machines illustrated are CE models.
Some illustrations of machines depict special equipment that is not included in the basic specification.
We reserve the right to make technical modifications.
© ALTENDORF® 2021
Order number K9690.0532. 12/2021